

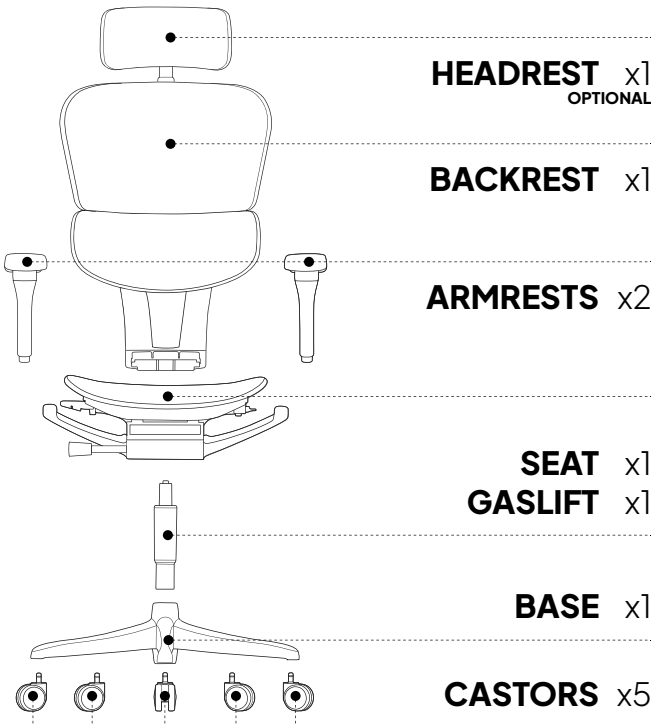

ASSEMBLY GUIDE ERGOHUMAN 2 ELITE

ERGOHUMAN AUSTRALIA



ALLEN KEY



SCREWS FOR ARMRESTS
4+1 SPARE
1/4 x 19/32"

SCREWS FOR BACKRESTS
4+1 SPARE
M8 x 15 mm

ASSEMBLE YOUR CHAIR

STEP 1

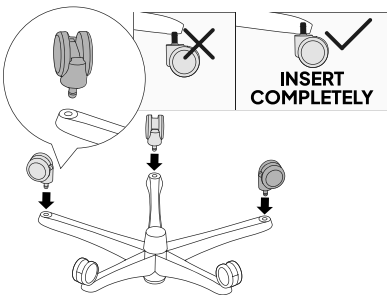

STEP 2

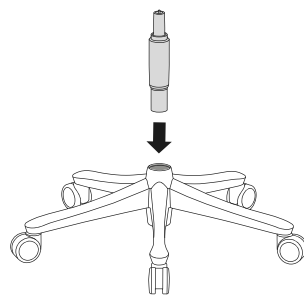

STEP 3

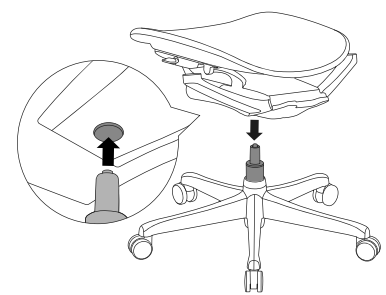

STEP 4

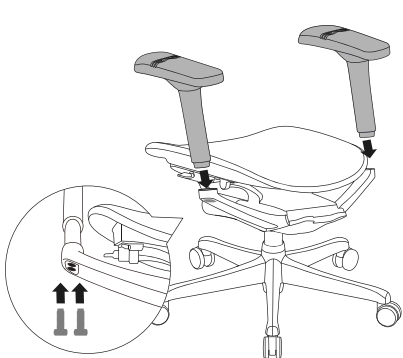

STEP 5

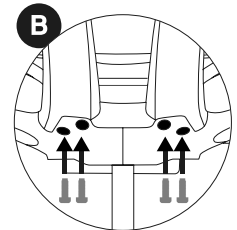
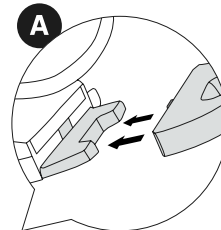



ADJUSTMENT GUIDE

ERGOHUMAN 2 ELITE



SEAT HEIGHT

Lever on right

To lower, lift lever while seated.
To raise, take your weight off chair and lift lever.



FORWARD SEAT TILT

Lever on left (free-float* mode on)

Push left lever down at the front and lean back to release forward seat tilt. Return right lever to neutral position to lock seat angle and back.



SEAT DEPTH

Lever on right

Push lever forward while seated. Slide seat until positioned with a 3 cm gap between front of the seat and the back of your legs.



ARMREST HEIGHT

Armrest ratchet

Lift or lower the armrests to your preferred height. This helps avoid shoulder and neck tension.

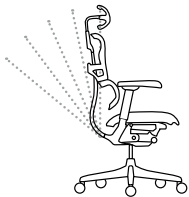

BACKREST RECLINE

Lever on right

Push the lever back while seated and recline. Leave lever back if using free-float mode*, or return to the centre to lock in one of 4 reclined positions.



ARMREST DEPTH

Armpad slide

Slide the armpads forwards or backwards for customised support of your forearms, taking pressure off your shoulders.



RECLINE TENSION

Long spindle on right

With the single lever pushed back, rotate long spindle forward to increase and backwards to reduce recline resistance.



ARMREST TILT

Armpad bend

Tilt up the front of your armrests for comfortable wrist support, ideal for when using handheld devices or reading a book.



BACK HEIGHT

Bar at rear of backrest

Reach behind the chair and lift or lower using the back bar to comfortably fit the backrest and lumbar to the shape of your spine.



ARMREST WIDTH

Armpad slide

Slide the armpads out or in so your shoulders and arms sit naturally by your side with your elbows close to your body.

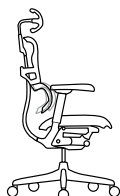

LUMBAR TENSION

Dial on backrest

Turn the dial to the left to strengthen the lumbar support's pressure, and to the right to reduce it.

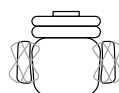

ARMREST ANGLE

Armpad twist

Pivot the armpads inwards and outwards to help you position your shoulders, neck, forearms, and hands for mouse and keyboard work.



HEADREST ANGLE

Pivot

Pivot the angle of the headrest to support your neck and head as you recline.



LEGREST EXTENSION

OPTION

Legrest handles

Turn the wheels at either sides to release the legrest. Lift the legrest frame and unfold out the mesh legrest.



HEADREST HEIGHT

Lift and lower

Lift or lower the headrest to fit comfortably into the curve of your neck.

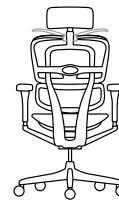

COAT HANGER

Pop up/down

Lift the arms to pop the coat hanger up, and press the button under the centre to drop the arms.





HEALTHY POSTURE

Ergohuman chairs are engineered to minimise pressure and tension on your back, neck, shoulders and thighs, reducing the risk of musculoskeletal issues and pain.

Use this guide to set up your chair correctly to promote healthy posture and enjoy the benefits working in an ergonomic chair.

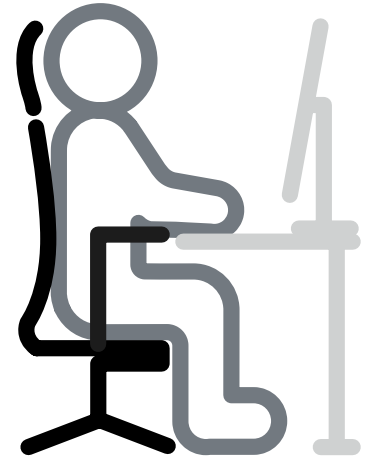

SEAT

- Adjust the seat height so your feet rest flat on the floor and your thighs are parallel to the floor. Your knees should be at a 90 degree angle.
- Adjust the seat depth to suit the length of your thighs and ensure there is a 3 cm gap between the seat front and the back of your knees.
- Activate the seat tilt feature to support your thighs when leaning in to your desk.

BACK & LUMBAR

- Adjust the recline tension to achieve the desired resistance of the backrest when leaning back in free-float mode.
- The backrest can be locked in position, but we recommend using free-float mode to encourage balanced and dynamic movement as you work.
- Set the back height so it supports the curves and natural alignment of your spine and lumbar region.
- Adjust the lumbar tension so the resistance is comfortable to support the natural alignment of your spine and to provide lower back comfort.

ARMRESTS

- Set the armrest height, width and depth so your arms comfortably make contact with the armpad. Your elbows should be close to your body and your shoulders relaxed.
- Pivot the chair's armpads in for support while using a keyboard or using a handheld device, and out to support mouse use.

HEADREST

- Set the height and angle of your headrest to support the curve between your neck and the back of your head.

LEGREST OPTION

- Elevate your legs when reclining using the fold-out legrest.
-